

COMMITTEE REPORT

Planning Committee on
Item No

18 November, 2015

Case Number

15/3316

SITE INFORMATION

RECEIVED: 3 August, 2015

WARD: Kilburn

PLANNING AREA: Kilburn & Kensal Consultative Forum

LOCATION: 42A-D and 43A-C St Julians Road, London, NW6 7LB

PROPOSAL: Proposed erection of mansard roofs with two front dormer windows and two rear dormer windows with inset balconies, to create two third floor flats (1x1bed) with front refuse storage to front of properties

APPLICANT: Genesis Housing Association

CONTACT: Nicholas Taylor + Associates

PLAN NO'S: See condition 2

SITE MAP



Planning Committee Map

Site address: 42A-D and 43A-C St Julians Road, London, NW6 7LB

© Crown copyright and database rights 2011 Ordnance Survey 100025260

This map is indicative only.

SELECTED SITE PLANS

SELECTED SITE PLANS



SCALE : 1:1250 @ A3

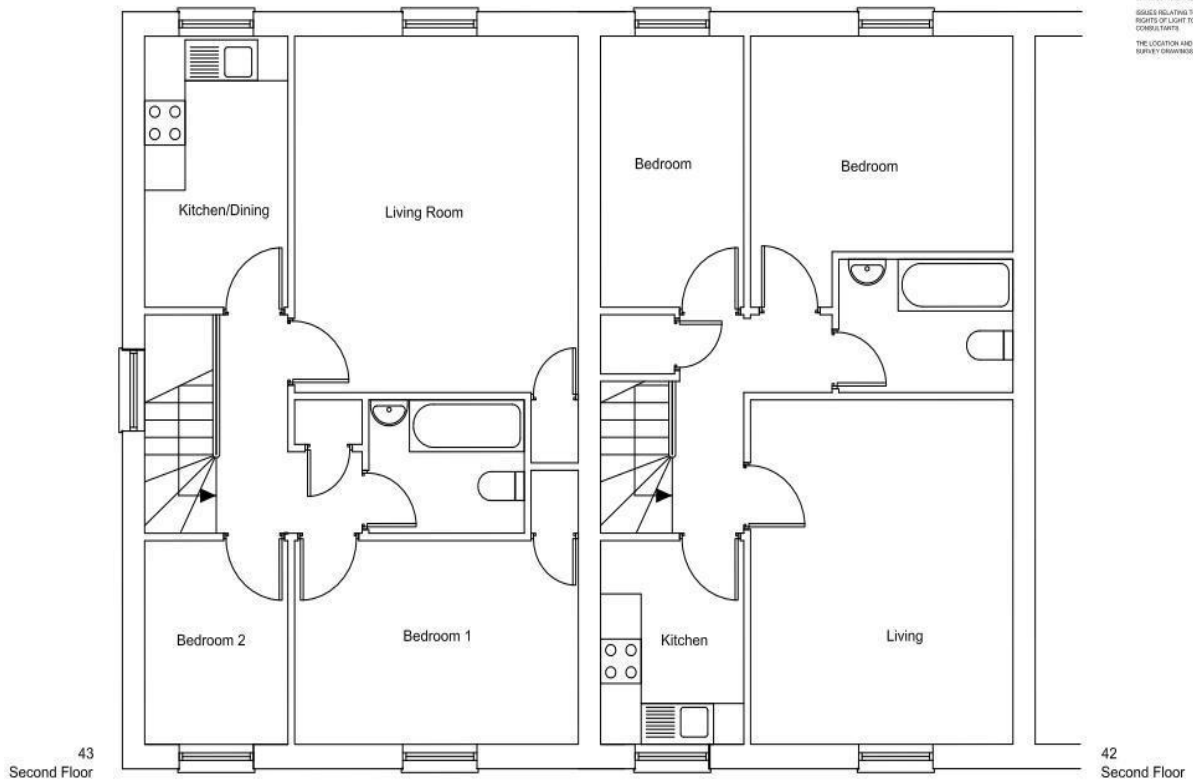

THIS DESIGN IS THE COPYRIGHT OF THE ARCHITECT AND IS NOT TO BE REPRODUCED OR TRANSMITTED IN ANY FORM OR BY ANY MEANS WITHOUT THE WRITTEN PERMISSION OF THE ARCHITECT. THE LOCATION AND SIZE OF EXISTING SURVEY ORIGINATING MUST BE PRELIMINARY.

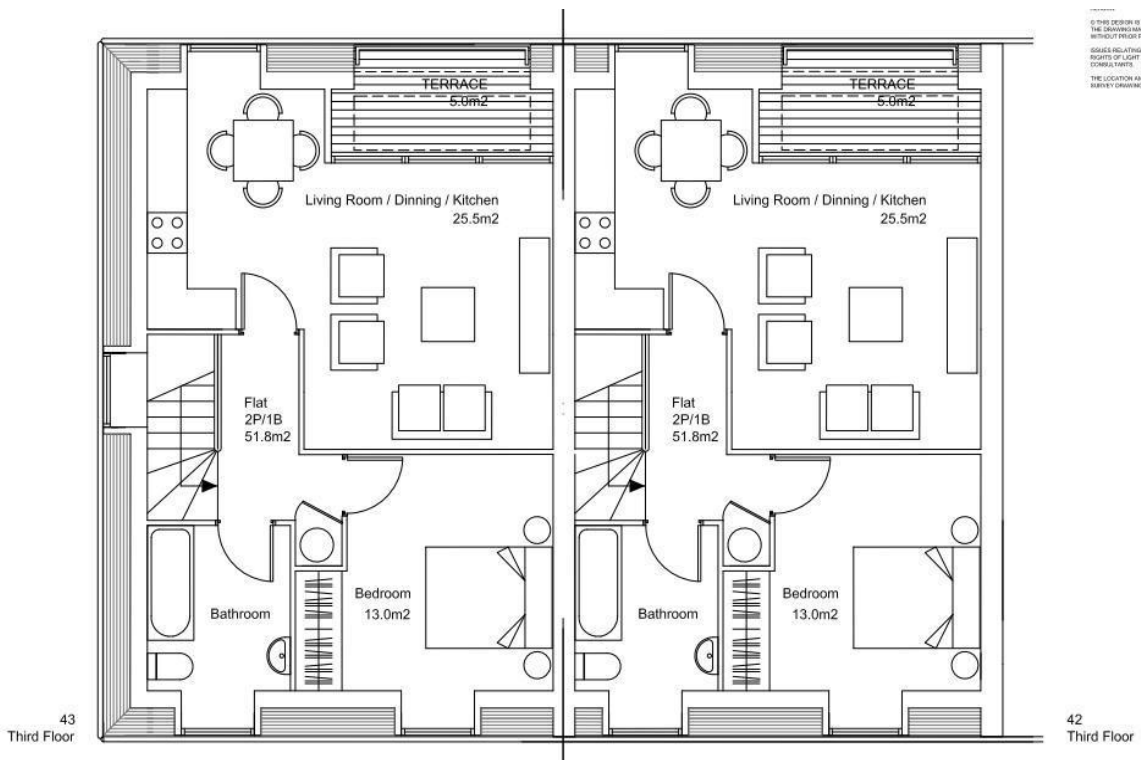
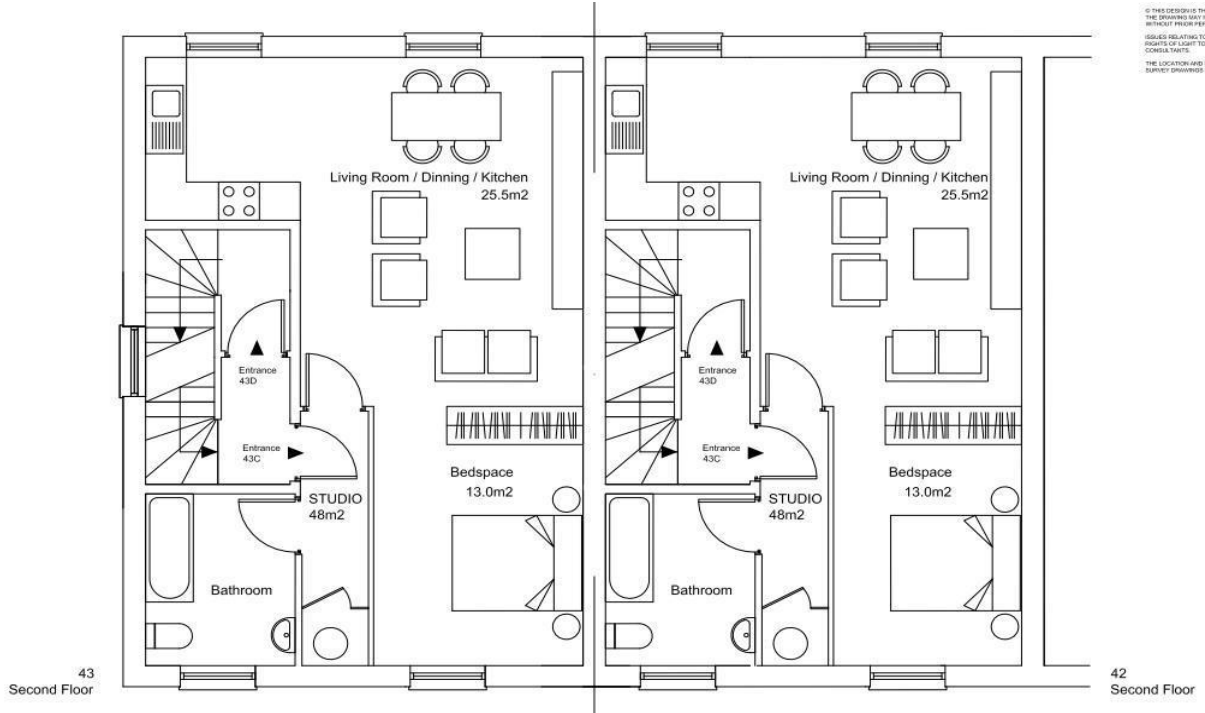



Planning permission for mansard sought simultaneously



Planning permission for mansard sought simultaneously



Planning permission for mansard sought simultaneously



Planning permission for mansard sought simultaneously

ISSUES IN
PROJECTS OF
CONSULT
THE LEGAL
SERVICES

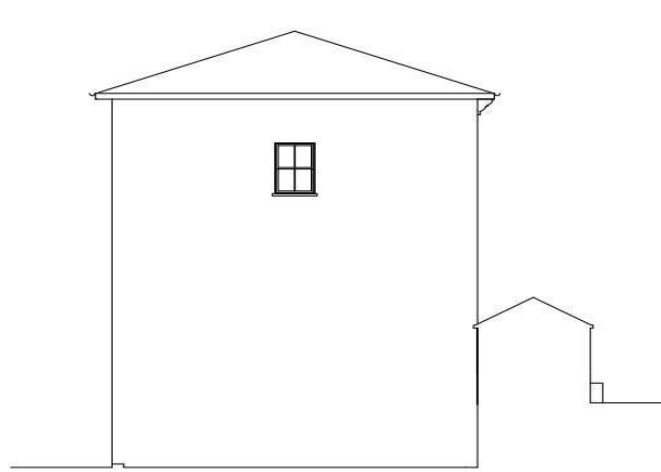

EXISTING SIDE ELEVATION - NO. 43

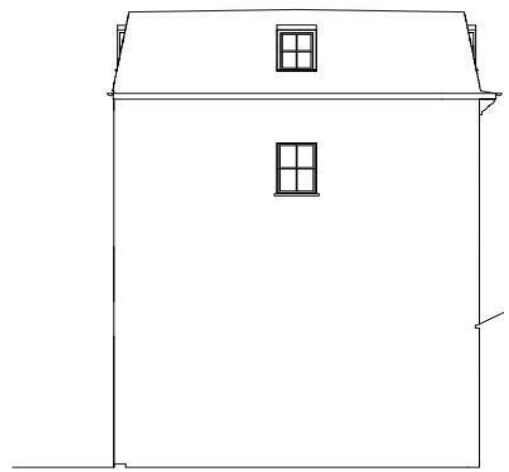

PROPOSED SIDE ELEVATION - NO. 43

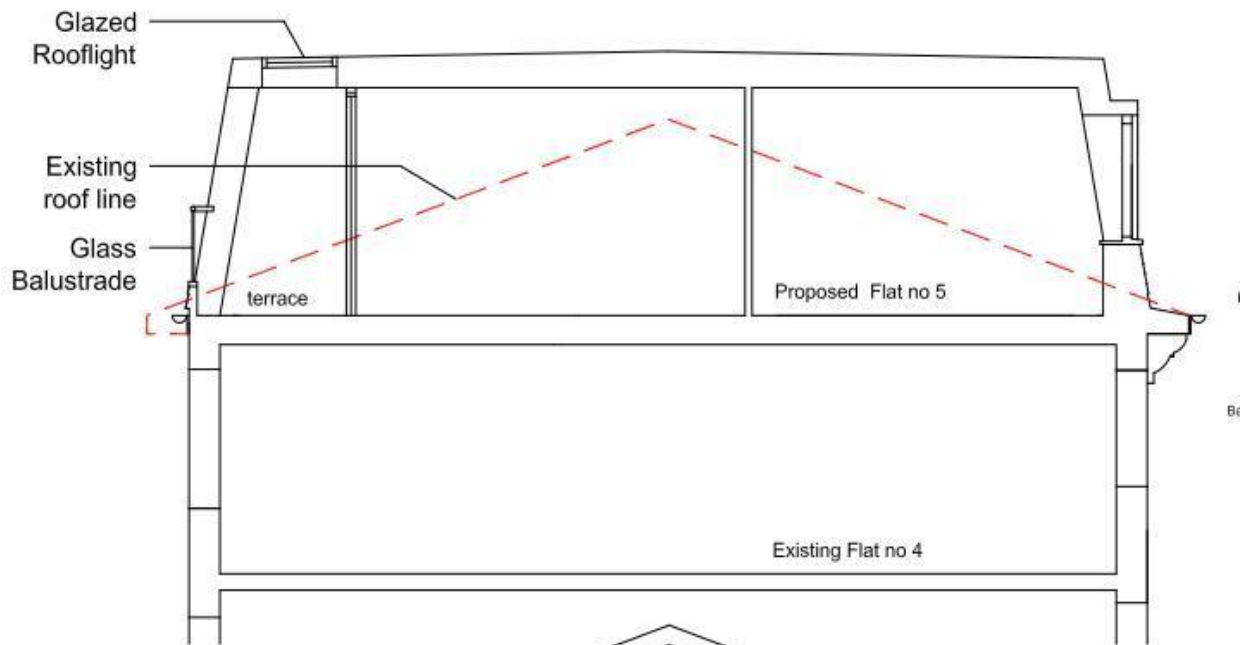

**PROPOSED SECTION
DETAIL**

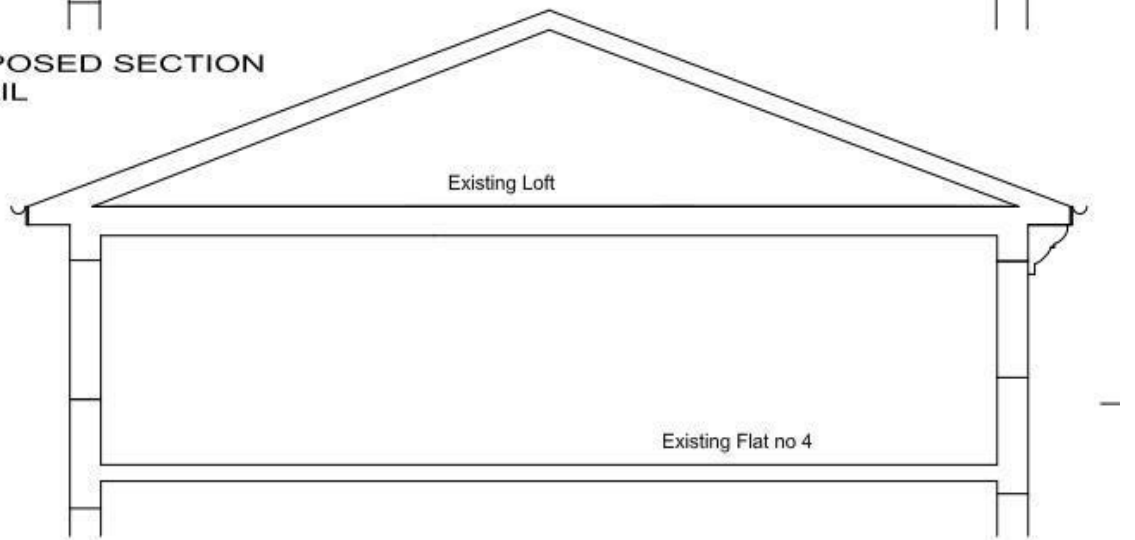

**EXISTING SECTION
DETAIL**

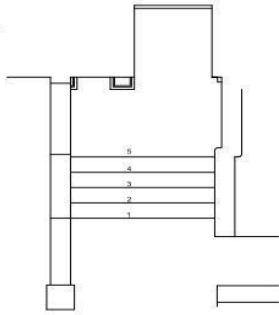

Existing refuse area 1:50 - Bins scattered freely at the entrance area

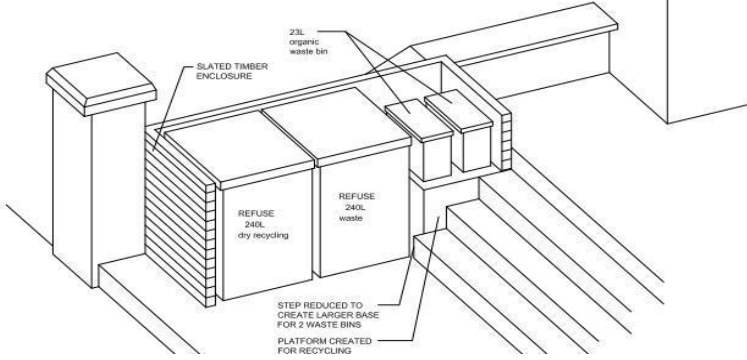

Refuse area sketch

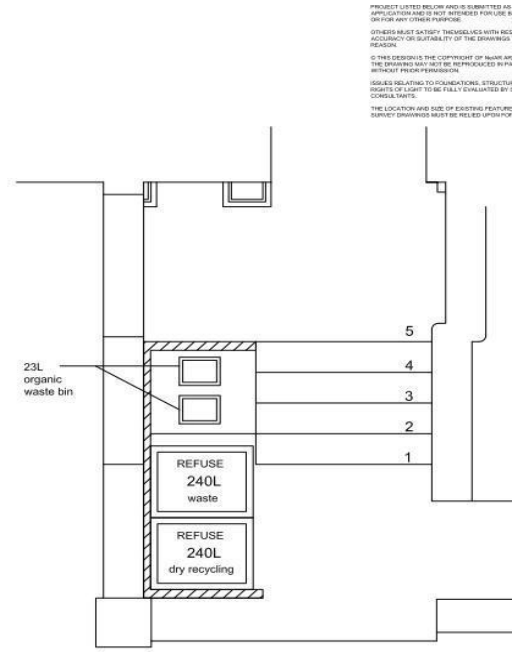

Refuse area plan 1:25

PROJECT LISTED BELOW AND IS SUBMITTED AS APPLICATION AND IS NOT BEING FORWARDED TO ANY OTHER PARTY.
OTHERS MUST SATISFY THEMSELVES WITH ACCURACY OR SUITABILITY OF THE DRAWINGS REASON.
THIS DESIGN IS THE PROPERTY OF HMM ARCHITECTS. THE DRAWINGS MAY NOT BE REPRODUCED IN ANY MANNER WITHOUT PRIOR PERMISSION.
ISSUES RELATING TO OPERATIONAL, STRUCTURAL, RIGHTS OF LIGHT TO BE FULLY EVALUATED BY CONSULTANTS.
THE LOCATION AND SIZE OF EXISTING FEATURE SURVEY DRAWINGS MUST BE REVERSED UPON FOR

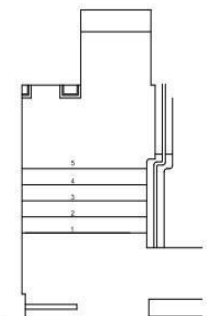

Existing refuse area 1:50 - Bins scattered freely at the entrance area

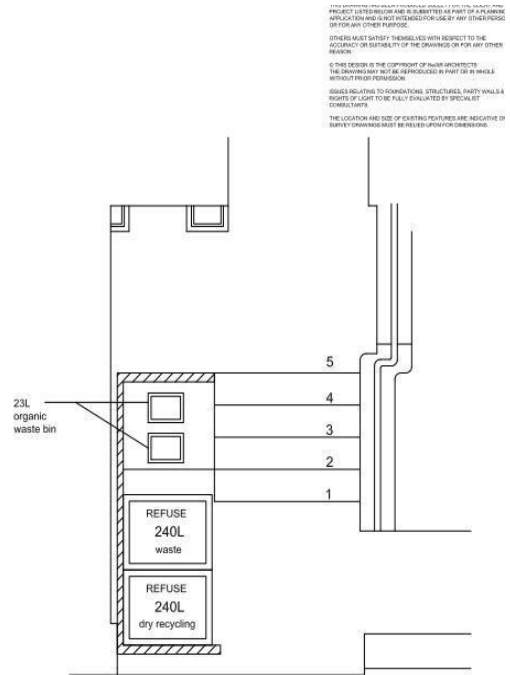
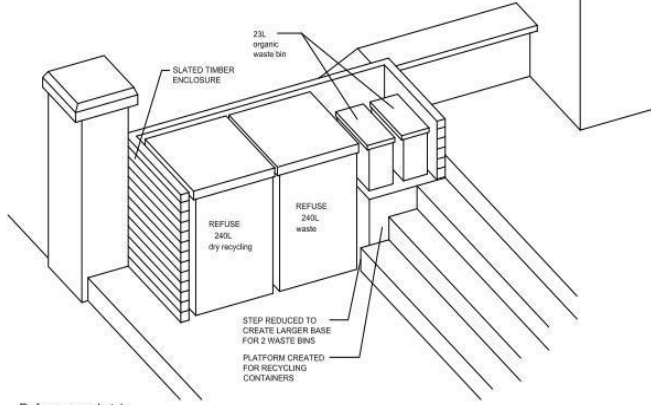

Refuse area plan 1:25

PROJECT LISTED BELOW AND IS SUBMITTED AS APPLICATION AND IS NOT BEING FORWARDED TO ANY OTHER PARTY.
OTHERS MUST SATISFY THEMSELVES WITH ACCURACY OR SUITABILITY OF THE DRAWINGS OR FOR ANY OTHER REASON.
THIS DESIGN IS THE PROPERTY OF HMM ARCHITECTS. THE DRAWINGS MAY NOT BE REPRODUCED IN ANY MANNER WITHOUT PRIOR PERMISSION.
ISSUES RELATING TO OPERATIONAL, STRUCTURAL, RIGHTS OF LIGHT TO BE FULLY EVALUATED BY CONSULTANTS.
THE LOCATION AND SIZE OF EXISTING FEATURE SURVEY DRAWINGS MUST BE REVERSED UPON FOR CORRECTIONS.



RECOMMENDATIONS

Approval, subject to the conditions set out in the Draft Decision Notice.

A) PROPOSAL

Proposed erection of mansard roofs with two front dormer windows and two rear dormer windows with inset balconies, to create two third floor flats (1x1bed) with front refuse storage to front of properties

B) EXISTING

The application site concerns Nos. 42 and 43 St Julians Road which consist of two three storey buildings with basements. No 42 is a mid terraced property and consists of four self contained flats whilst No. 43 is an end of terrace property and consists of three self contained flats. The application site is not located within a conservation area nor does any part contain a listed building.

C) AMENDMENTS SINCE SUBMISSION

D) SUMMARY OF KEY ISSUES

The key issues are as follows:

1. The impact of the proposed terrace on neighbouring properties
2. The impact of the proposal on refuse
3. The impact of the proposal on transport (this is negated due to the proposal being 'car-free')

RELEVANT SITE HISTORY

10/2289 – GTD

Erection of front and rear mansard roof, with 2 dormer windows at front and 2 at rear, to create 1 two-bedroom flat at third-floor level of each property, with associated refuse-storage area to front of flats and subject to a Deed of Agreement dated 07/04/11 under Section 106 of the Town and Country Planning Act 1990, as amended

09/1592 – DIS

Erection of front and rear mansard roof extension with 2 front and 2 rear dormer windows to each property to create 2 x two bedroom self contained flats.

08/3380 – REF

Front and rear mansard roof extension with 2 front and 2 rear dormer windows to each property to create 2 self-contained, two-bedroom flats.

07/2795 – REF

Front and rear mansard roof extension with 2 x front and 2 x rear dormer windows to each property to create 2 x self-contained, two-bedroom flats.

01/1471 – GTD

Joining basement flat 42a to basement of flat 43a to form a single dwelling

CONSULTATIONS

Consultation period: 14/08/2015 – 04/09/2015

Fifty neighbouring properties were consulted. To date one representation has been received which raised the following points:

Objection	Response
Refuse storage	See paragraph 10 and 18
Impact on parking	See paragraph 16
Damage during construction phase	See paragraph 11
Structural problems	See paragraph 11
Overlooking/loss of privacy	See paragraph 9

POLICY CONSIDERATIONS

NPPF 2012

London Plan 2015

3.5 Quality and Design of Housing Developments

Core Strategy 2010

CP21 A Balanced Housing Stock

UDP 2004

BE2 Townscape: Local Context & Character
BE3 Urban Structure: Space & Movement
BE6 Public Realm: Landscape Design
BE7 Public Realm: Streetscape
BE9 Architectural Quality
H12 Residential Quality – Layout Considerations
TRN3 Environmental Impact of Traffic
TRN11 The London Cycle Network
TRN23 Parking Standards – Residential Developments
TRN24 On-street Parking
PS14 Residential Development
PS16 Cycle Parking Standards

Supplementary Planning Guidance

SPG17: 'Design Guide for New Development'
Mayor of London's Housing SPG

DETAILED CONSIDERATIONS

Introduction

1. Application 15/3316 proposes the erection of a mansard roof with front and rear dormers and inset rear balconies to create two one-bedroom flats at third floor level with associated refuse-storage area by the front entrance for both 42 and 43 St Julians Road. As explained in the 'History' section of this report permission was granted for the erection of two mansard roof extensions under application 10/2289. Prior to the granting of permission for application 10/2289 permission was refused for a similar application under application 09/1592 and subsequently dismissed at appeal. Although the Council refused the application on design grounds, the standard of accommodation, the impact on parking and the absence of a legal agreement to control parking the Planning Inspectorate found that the application was acceptable on design grounds and was visually appropriate due to the number of similar developments on St Julians Road. The Council need to take account of the Inspectors views with regard to design and as the current application is based on the

design of the previously approved application the Council is once again led by the findings of the Inspector.

Site layout and access

2. Currently the buildings consists of four self contained flats in No.42 set out over basement, ground, first and second floor levels and three self contained flats in No. 43 set out over ground, first and second floor levels. The current application proposes the addition of a fourth and fifth self contained flat on the third floor consisting of a one bedroomed unit with living/kitchen area, bedroom, bathroom and terrace to provide amenity space. The proposed flats will be accessed via the existing front doorway at ground floor level with the existing stairs continuing from the second floor. This will result in a reduction of space for the existing second floor flat which will be converted from a two bed unit to a 48 sqm studio flat.

Design, scale and massing

3. As mentioned in the introduction section of this report the Council previously found that the proposed roof extension submitted under application 09/1592 would have resulted in an incongruous addition that would appear visually obtrusive and unsympathetic to the scale, design and appearance of the property and its surroundings. However during the course of the appeal the Inspector found the proposal to be visually appropriate when compared to similar developments on St Julians Road and went on to find the rear views of the property to be limited by the extant buildings in Priory Park Road, Aldershot Road and Opel Mews. The Inspector therefore concluded that there would be no harm to the original building or the character of the area and two mansard roof extensions were approved under planning application 10/2304.

4. The current application replicates the design of the application that was previously approved. Therefore once again whilst officers might have disagreed with the Inspectors findings at the time, consideration must be given to the Inspectors views. As such, officers consider that it would be difficult to object to the roof alterations in principle. The proposal will see an increase in height of 0.7 metres from the existing roof however the width will be slightly reduced when viewed from the side elevation. During discussions with the applicant a parapet wall has been agreed on the front elevation of each building which will help to reduce the visual impact of the proposal by providing a break between the roof addition and the third floor.

Standard of accommodation

5. Policy 3.5 of the London Plan (2015) of the London Plan sets out the minimum internal space standards that are appropriate for new developments in order to provide a satisfactory standard of accommodation for future occupants. The application proposes the addition of two one bed units with Gross Internal Areas (GIA) of 51.8 sqm which slightly exceeds the minimum GIA of 50 sqm.

6. The Mayor of London's Housing SPG contains guidance with regard to the standard of accommodation that new development should provide. With regard to private amenity space a minimum of 5 sqm of private outdoor space should be provided for 1-2 person dwellings. The application has proposed 5 sqm terraces for each flat that will be accessed from the living/kitchen area in both units which complies with this standard.

7. The bedroom and kitchen/living room areas are of generous sizes and exceed the minimum size standard as contain in the Housing SPG. With regard to outlook and access to natural light the living/kitchen areas are well served by the roof terraces and windows and the bedrooms are also served by the dormer windows. National Housing Standards require rooms to have headroom of 2.5 metres in 75% of the room. The proposed flats will have headroom heights of 2.35 metres however due to the proposed flat exceeding the minimum GIA and the inclusion of private amenity space this is acceptable in this case. With regard to stacking the layout of the proposed unit at third floor level has been set out to match that of the proposed studio flat at second floor level.

8. The proposal will involve the loss of two one bedroomed units at second floor level and see them replaced with 48 sqm studio flats. Policy 3.5 of the London Plan (2015) of the London Plan states that a studio flat with separate shower room or bathroom must have a minimum GIA of 39 sqm. The second floor studio flats will exceed this standard and will have good access to natural light from the existing windows. The lack of

amenity space can be offset by the increased GIA and due to the fact that the existing flats do not have access to any amenity space. The proposed studio flats at second floor level are therefore deemed to be acceptable.

Impact on neighbouring amenity

9. Residential units are located on all floors of the application site and on either side in the adjoining buildings. There are also residential units located to the rear in Opal Mews and Aldershot Road. Concerns have been raised by a number of neighbouring residents regarding the issue of overlooking and loss of privacy from the balcony. However the proposed terrace would be flush with the rear elevation of the building and as such residents would be restricted from overlooking.

10. Concerns have been raised about the impact on refuse storage. However the proposal will see the introduction of a communal refuse storage that will improve the current situation where refuse is stored in wheelie bins on the street.

11. Although concerns have been raised about structural damage and damage during the construction phase, unfortunately this is not a planning consideration that can be taken into account and is controlled by other legislation. In the event that permission is granted conditions can be attached requiring the applicant to sign up to the Considerate Contractors Scheme whilst a Construction Method Statement will also be required.

Transport Considerations

12. Car parking allowances for the combined buildings are currently 5.4 spaces due to the presence of seven flats. The proposal to provide two one-bedroom flats at third floor level would increase the parking standard by 1.4 spaces to 6.8 spaces. This is considered to be a significant increase and no off-street parking space is available to meet this increase in standard.

13. In cases where the residential parking standard cannot be met within the site, Policy TRN23 requires the impact on on-street parking to be considered, with on-street parking permitted to be counted towards meeting demand where the site fronts a local access road that is not heavily parked and has sufficient width to accommodate unobstructive parking. In this case St. Julian's Road is already noted as being heavily parked at night and is unable to safely accommodate additional parking from this building.

14. To address this, the applicant proposes a S106 'car-free' Agreement to remove the right of future residents of the new flat to on-street parking permits in the area. This is consistent with Policy TRN23, which does allow 'car-free' developments in exceptional cases, where the site is located within a CPZ and has good access to public transport services.

15. Concerns were expressed at the time of the previous consent regarding the practical enforceability of a 'car-free' agreement that applies to only one flat within the building, with problems having arisen in other cases where buildings contain a mixture of flats that are and are not eligible for permits. This continues to be the Council's approach to proposals of this kind, however these concerns were not considered to be so significant by the Planning Inspector at the time of the appeal so as to justify the dismissal of the appeal and a new third-floor two-bedroom flat at third floor level was subsequently granted.

16. The parking permit system has been transferred to an online system, which means this issue can be more easily dealt with provided the affected flats can still be readily identified and there are no unauthorised changes to the layout of the units within the building. Only the third floor of the building will be affected by the proposed agreement which will make it easier to identify the future address of the affected flat. As such, in light of the previous permission, this proposal can be accepted subject to a new S106 'car-free' Agreement. Concerns have been raised by an objector about the potential impact on car parking in the area however the applicant has proposed making the additional units 'car free' which is deemed as being acceptable.

17. Standard PS16 requires at least one secure cycle parking space per flat, where practical. However, there is no realistic scope to meet this requirement within the frontage of the site. As not all units would have access to the rear garden this requirement can therefore be waived.

Refuse

18. As previously mentioned, currently the refuse storage situation sees wheelie bins stored on the footpath which is not ideal in terms of safety as it blocks pedestrians. The proposal will see the construction of a designated bin storage area capable of storing two 240L bins for dry recycling and refuse and two 23L organic waste bins for each building. Concerns have been raised about refuse storage by neighbouring residents and the proposal should see an improvement in how the bins are stored by providing residents with a designated area where bins can be placed after collection. This will also help to improve highway safety for pedestrians.

Conclusion

19. Taking into consideration the history of the site and the previous decision of the Planning Inspectorate regarding the design of the proposal the addition of mansard roofs would be acceptable in this case.

20. The proposed roof extensions will provide two additional units that are of an acceptable standard in terms of the standard of accommodation they would provide and comply with the necessary policies and guidance as contained in the London Plan (2015). The proposal will provide appropriate additions to the existing buildings that meet parking standards and the new floor areas will be liable to CIL.

CIL DETAILS

This application is liable to pay **£36,433.55*** under the Community Infrastructure Levy (CIL).

We calculated this figure from the following information:

Total amount of eligible** floorspace which on completion is to be demolished (E): sq. m.

Total amount of floorspace on completion (G): 134 sq. m.

Use	Floorspace on completion (Gr)	Eligible* retained floorspace (Kr)	Net area chargeable at rate R (A)	Rate R: Brent multiplier used	Rate R: Mayoral multiplier used	Brent sub-total	Mayoral sub-total
Dwelling houses	134		134	£200.00	£35.15	£30,987.50	£5,446.05
			0	£0.00	£0.00	£0.00	£0.00

BCIS figure for year in which the charging schedule took effect (Ic)	224	224
BCIS figure for year in which the planning permission was granted (Ip)	259	
Total chargeable amount	£30,987.50	£5,446.05

*All figures are calculated using the formula under Regulation 40(6) and all figures are subject to index linking as per Regulation 40(5). The index linking will be reviewed when a Demand Notice is issued.

****Eligible** means the building contains a part that has been in lawful use for a continuous period of at least six months within the period of three years ending on the day planning permission first permits the chargeable development.

Please Note : CIL liability is calculated at the time at which planning permission first permits development. As such, the CIL liability specified within this report is based on current levels of indexation and is provided for indicative purposes only. It also does not take account of development that may benefit from relief, such as Affordable Housing.

DRAFT DECISION NOTICE



Brent

DRAFT NOTICE

TOWN AND COUNTRY PLANNING ACT 1990 (as amended)

DECISION NOTICE – APPROVAL

Application No: 15/3316

To: Taylor
Nicholas Taylor + Associates
31
Windmill Street
London
W1T 2JN

I refer to your application dated 03/08/2015 proposing the following:
Proposed erection of mansard roofs with two front dormer windows and two rear dormer windows with inset balconies, to create two third floor flats (1x1bed) with front refuse storage to front of properties

and accompanied by plans or documents listed here:
See condition 2
at 42A-D and 43A-C St Julians Road, London, NW6 7LB

The Council of the London Borough of Brent, the Local Planning Authority, hereby GRANT permission for the reasons and subject to the conditions set out on the attached Schedule B.

Date:

Signature:

Head of Planning, Planning and Regeneration

Notes

1. Your attention is drawn to Schedule A of this notice which sets out the rights of applicants who are aggrieved by the decisions of the Local Planning Authority.
2. This decision does not purport to convey any approval or consent which may be required under the Building Regulations or under any enactment other than the Town and Country Planning Act 1990.

DnStdG

SUMMARY OF REASONS FOR APPROVAL

- 1 The proposed development is in general accordance with policies contained in the:-
Brent Unitary Development Plan 2004
Council's Supplementary Planning Guidance 17 Design Guide for New Development
Relevant policies in the Adopted Unitary Development Plan are those in the following chapters:-
Built Environment: in terms of the protection and enhancement of the environment
Environmental Protection: in terms of protecting specific features of the environment and protecting the public
Housing: in terms of protecting residential amenities and guiding new development
Transport: in terms of sustainability, safety and servicing needs

- 1 The development to which this permission relates must be begun not later than the expiration of three years beginning on the date of this permission.
Reason: To conform with the requirements of Section 91 of the Town and Country Planning Act 1990.

- 2 The development hereby permitted shall be carried out in accordance with the following approved drawing(s) and/or document(s):
0315/SJR/001
0315/SJR/100
0315/SJR/101
0315/SJR/110
0315/SJR/111
0315/SJR/112
0315/SJR/200
0315/SJR/201
0315/SJR/202
0315/SJR/210
0315/SJR/211 Proposed Rear Elevation
0315/SJR/211 Proposed Side Elevation
0315/SJR/212
0315/SJR/310
0315/SJR/410

Reason: For the avoidance of doubt and in the interests of proper planning.

- 3 Occupiers of the residential development, hereby approved, shall not be entitled to a Residents Parking Permit or Visitors Parking Permit to allow the parking of a motor car within the Controlled Parking Zone (CPZ) operating in the locality within which the development is situated unless the occupier is entitled; to be a holder of a Disabled Persons Badge issued pursuant to Section 21 of the Chronically Sick and Disabled Persons Act 1970. For the lifetime of the development written notification of this restriction shall be included in any licence transfer lease or tenancy agreement in respect of the residential development. For the lifetime of the development a notice, no smaller than 30cm in height and 21cm in width, clearly informing occupants of this restriction shall be displayed within the ground floor communal entrance lobby, in a location and at a height clearly visible to all occupants. On, or after, practical completion but prior to any occupation of the residential development, hereby approved, written notification shall be submitted to the Local Highways Authority confirming the completion of the development and that the above restriction will be imposed on all future occupiers of the residential development.

Reason: In order to ensure that the development does not result in an increased demand for parking that cannot be safely met within the locality of the site.

- 4 No development shall be carried out until the person carrying out the works is a member of the Considerate Constructors Scheme and its code of practice, and the details of the membership and contact details are clearly displayed on the site so that they can be easily read by members of the public.

Reason: To limit the impact of construction upon the levels of amenity that neighbouring occupiers should reasonably expect to enjoy.

- 5 Prior to the commencement of works, a Construction Method Statement shall be submitted to and approved in writing by the Local Planning Authority detailing measures that will be taken to control dust, noise and other environmental impacts of the development and the routing and timing of construction vehicles and the approved details shall thereafter be implemented.

Reason: To safeguard the amenity of the neighbours by minimising impacts of the development that would otherwise give rise to nuisance and to mitigate against highways impacts.

- 6 No development shall take place before a scheme for adequate sound insulation to walls and/or floors between units in separate occupation hereby approved has been submitted in addition to building regulations and approved in writing by the Local Planning Authority. Thereafter none of the flats shall be occupied until the approved scheme has been fully implemented.

Reason: In the interests of residential amenity

INFORMATIVES

- 1 The provisions of The Party Wall etc. Act 1996 may be applicable and relates to work on an existing wall shared with another property; building on the boundary with a neighbouring property; or excavating near a neighbouring building. An explanatory booklet setting out your obligations can be obtained from the Communities and Local Government website www.communities.gov.uk

Any person wishing to inspect the above papers should contact Barry Henn, Planning and Regeneration, Brent Civic Centre, Engineers Way, Wembley, HA9 0FJ, Tel. No. 020 8937 5232